

Product category: PRO300 (3" flange RedHeader PRO) As Header
Product name: **600PRO300-33 (33ksi, CP60) - Unpunched**
 33mils (20ga) Coating: CP60 per ASTM C955

Geometric Properties

Web depth	6.000 in	Design thickness	0.0346 in
Flange width	3.000 in	Min. steel thickness	0.0329 in
Stiffening lip	1.000 in	Yield strength, Fy	33 ksi

Gross Section Properties of Full Section, Strong Axis

Cross sectional area (A)	0.474 in ²
Member weight per foot of length	1.61 lb/ft
Moment of inertia (Ix)	2.816 in ⁴
Section modulus (Sx)	0.939 in ³
Radius of gyration (Rx)	2.437 in
Gross moment of inertia (Iy)	0.652 in ⁴
Gross section modulus (Sy)	0.337 in ³
Gross radius of gyration (Ry)	1.173 in

Effective Section Properties, Strong Axis

Moment of inertia for deflection (Ixe)	2.572 in ⁴
Moment of inertia for deflection (Iye*)	0.503 in ⁴
Section modulus (Sxe)	0.653 in ³
Section modulus (Sye*)	0.275 in ³
Allowable bending moment (Max - Local)	12.89 in-k
Allowable bending moment (May - Local*)	5.43 in-k
Allowable bending moment (Max - Distortional)	13.92 in-k
Allowable bending moment (May - Distortional*)	5.01 in-k
Allowable shear force in web (Vax)	638 lb

Torsional Properties

St. Venant torsion constant (J x 1000)	0.189 in ⁴
Warping constant (Cw)	5.749 in ⁶
Distance from shear center to neutral axis (Xo)	-2.598 in
Radii of gyration (Ro)	3.750 in
Torsional flexural constant (Beta)	0.520

Section Property Notes

* Iye, Sye, and May are for a positive moment with the return lips in compression.
 (Installing the header with the flanges pointing up)

ASTM & Code Standards:

- AISI S100-12 and S100-07 w/S2-10 supplements
- Effective properties incorporate the strength increase from cold work of forming
- Structural framing is produced to meet or exceed ASTM C955
- Sheet steel meets or exceeds mechanical and chemical requirements of ASTM A1003
- SDS & Product Certification Information is available at www.clarkdietrich.com

Sustainability Credits For more details and LEED letters contact Technical Services at 888-437-3244 or visit clarkdietrich.com/LEED.

LEED v4.1 MR Credit: Environmental Product Declarations: EPD (1 point) - Sourcing of Raw Materials (up to 2 points) - Material Ingredients (1 point) - Construction and Demolition Waste Management (up to 2 points)

LEED v4 MR Credit: Building Product Disclosure and Optimization: EPD (1 point) - Sourcing of Raw Materials (1 point) - Material Ingredients (1 point) - Construction and Demolition Waste Management (up to 2 points) - Innovation Credit (up to 2 points).

05.40.00 (Cold-Formed Metal Framing)

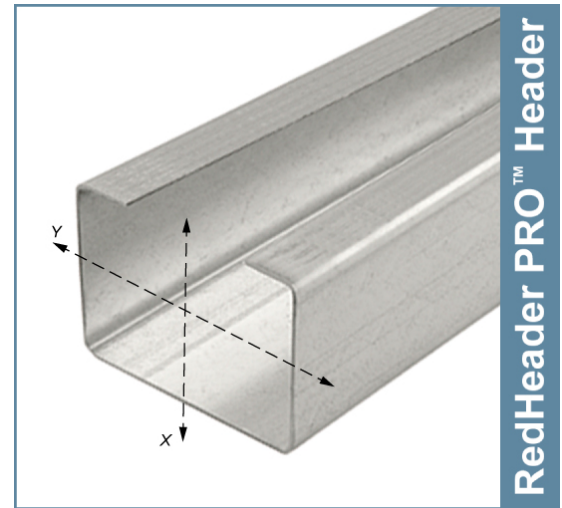

RedHeader PRO™ Header

- Replaces lay-in and boxed headers.
- Reduces material pieces, weight & screws.
- Insulation installs quicker.

Ordering Information:

Header lengths should be ordered ½" shorter to fit inside HDSC Header Brackets.
 (Header length = inside of jamb to inside of jamb - ½")

HDSC Header Bracket profile data:

See HDSC Header Bracket submittal sheet for allowable clip loads. All headers require the attachment of the HDSC Clip at each end with headers installed leg up.

Project Information

Name:
Address:

Contractor Information

Name:
Contact:
Phone:
Fax:

Architect Information

Name:
Contact:
Phone:
Fax:

Product category: PRO300 (3" flange RedHeader PRO) As Jamb
Product name: 600PRO300-33 (33ksi, CP60) - Punched
 33mils (20ga) Coating: CP60 per ASTM C955

Geometric Properties

Web depth	6.000 in	Design thickness	0.0346 in
Flange width	3.000 in	Min. steel thickness	0.0329 in
Stiffening lip	1.000 in	Yield strength, Fy	33 ksi

Gross Section Properties of Full Section, Strong Axis

Cross sectional area (A)	0.474 in ²
Member weight per foot of length	1.61 lb/ft
Moment of inertia (Ix)	2.816 in ⁴
Section modulus (Sx)	0.939 in ³
Radius of gyration (Rx)	2.437 in
Gross moment of inertia (Iy)	0.652 in ⁴
Gross section modulus (Sy)	0.337 in ³
Gross radius of gyration (Ry)	1.173 in

Effective Section Properties, Strong Axis

Moment of inertia for deflection (Ixe)	2.572 in ⁴
Section modulus (Sxe)	0.653 in ³
Allowable bending moment (Max - Local)	12.89 in-k
Allowable bending moment (Max - Distortional)	13.92 in-k
Allowable shear force in web (Vax)	638 lb

Torsional Properties

St. Venant torsion constant (J x 1000)	0.189 in ⁴
Warping constant (Cw)	5.749 in ⁶
Distance from shear center to neutral axis (Xo)	-2.598 in
Radii of gyration (Ro)	3.750 in
Torsional flexural constant (Beta)	0.520

Unbraced length (Lu) 81.1 in

ASTM & Code Standards:

- AISI S100-12 and S100-07 w/S2-10 supplements
- Effective properties incorporate the strength increase from cold work of forming
- Structural framing is produced to meet or exceed ASTM C955
- Sheet steel meets or exceeds mechanical and chemical requirements of ASTM A1003
- SDS & Product Certification Information is available at www.clarkdietrich.com

05.40.00 (Cold-Formed Metal Framing)

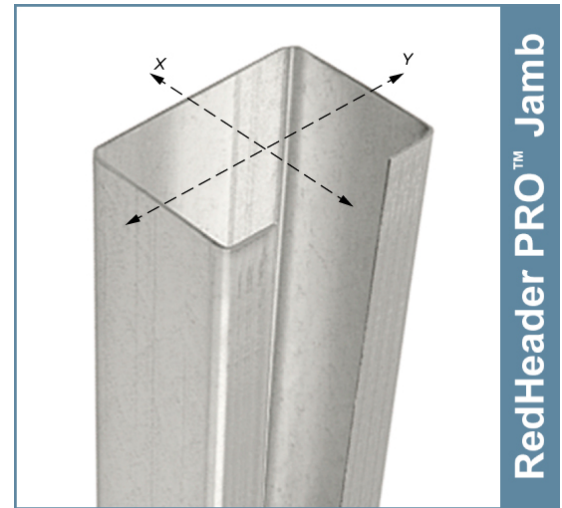

RedHeader PRO™ Jamb

- Eliminates and/or minimizes built-up jambs.
- Reduces material pieces, weight & screws.
- Opened jamb does not require pre-insulating.



Sustainability Credits For more details and LEED letters contact Technical Services at 888-437-3244 or visit clarkdietrich.com/LEED.

LEED v4.1 MR Credit: Environmental Product Declarations: EPD (1 point) - Sourcing of Raw Materials (up to 2 points) - Material Ingredients (1 point) - Construction and Demolition Waste Management (up to 2 points)

LEED v4 MR Credit: Building Product Disclosure and Optimization: EPD (1 point) - Sourcing of Raw Materials (1 point) - Material Ingredients (1 point) - Construction and Demolition Waste Management (up to 2 points) - Innovation Credit (up to 2 points).

Project Information

Name:
Address:

Contractor Information

Name:
Contact:
Phone:
Fax:

Architect Information

Name:
Contact:
Phone:
Fax: