

Medium Clip Angle

CDCA23G

12ga angles used to attach back-to-back installation. The staggered hole pattern minimizes wood splitting.

Product Data & Ordering Information:

| | |
|-----------------------|---|
| Material | Structural Grade 50 Type H (ST50H), 50ksi (340 MPa) |
| Coating | G185 |
| Thickness | 12ga (97mil), 0.1017" Design thickness, 0.0966" Minimum thickness |
| Dimensions | 2-7/64" x 3" |
| Packaging | 15 pcs/ctn |
| Product weight | 0.35 lb/ea |

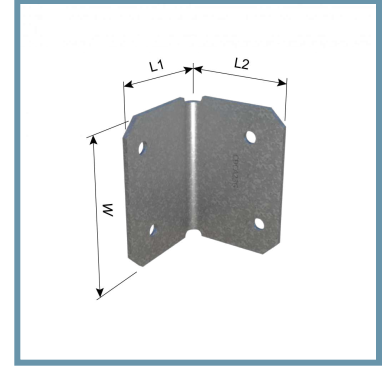

| Product Code | Gauge | Dimensions (in) | | | Fastener Scheduling | | | | Load | Allowable Loads | | | | |
|--------------|-------|-----------------|--------|---|---------------------|------|-------|------|----------------|-----------------|------------------|------------------|------------------|------------------|
| | | L1 | L2 | W | Header | | Joist | | | Dir | C _D = | C _D = | C _D = | C _D = |
| | | | | | Qty | Type | Qty | Type | | | 1.00 | 1.15 | 1.25 | 1.60 |
| CDCA23G | 12 | 2-7/64 | 2-7/64 | 3 | 2 | WS15 | 2 | WS15 | F ₁ | 425 | 425 | 425 | 425 | |

Notes:

For SI: 1 inch = 25.4 mm, 1 pound (lb) = 4.45 N

1 The tabulated allowable loads are for a single angle. If a single angle is installed on each end of a supported member, the angles must be installed on opposite sides of the supported member, or wood blocking must be installed to prevent rotation.

2 The tabulated allowable loads have been adjusted for the load duration factors, C_D, as shown, in accordance with the NDS. The tabulated allowable loads do not apply to loads of other load durations, and are not allowed to be adjusted for other load durations. See Sections 4.1 and 4.2 in ESR-0579 for additional design and installation requirements.

3 The tabulated allowable loads are for installations on wood members complying with Section 3.2.2 of the ESR-5079 report.

4 The tabulated allowable uplift loads have been increased for wind and seismic loading with no further increase is allowed. The tabulated allowable uplift loads must be reduced when other load duration govern.

5 See images below for hanger dimension definitions of W, L1 and L2.

6 WS15 Wood Screws (ESR-2761) are 1/4 inch diameter by 1-1/2 inches long and shipped with CDCA angles.

7 F₁ is the vertical load.



Code Approvals & Performance Standards

- [ASTM A653](#) Standard Specification for Steel Sheet, Zinc-Coated (Galvanized) or Zinc-Iron Alloy-Coated (Galvannealed) by the Hot-Dip Process
- [ASTM A1003](#) Standard Specification for Steel Sheet, Carbon, Metallic- and Nonmetallic-Coated for Cold-Formed Framing Members
- [ICC-ES ESR-5079](#) Evaluation report for clips, angles and hurricane ties
- [SDS For ASTM A1003 Steel Framing Products](#) For Interior Framing, Exterior Framing and Clips/Accessories

Sustainability Credits For more details and LEED letters contact Technical Services at 888-437-3244 or visit clarkdietrich.com/LEED.

- **LEED v4.1 MR Credit:** Environmental Product Declarations: EPD (1 point) - Sourcing of Raw Materials (up to 2 points) - Material Ingredients (1 point) - Construction and Demolition Waste Management (up to 2 points)
- **LEED v4 MR Credit:** Building Product Disclosure and Optimization: EPD (1 point) - Sourcing of Raw Materials (1 point) - Material Ingredients (1 point) - Construction and Demolition Waste Management (up to 2 points) - Innovation Credit (up to 2 points).